

Van's Aircraft
RV-9
ECI O-320-B1A1N

Pilot's Operating Handbook

N178TL

RV-9 N178TL

Pilot Operating Handbook



Enclosed is the POH that I developed during the flight testing of my RV-6A. It is roughly based on a typical Cessna POH, with modifications specific to an RV. There are also specific references to my tail number and equipment installed in my RV-6A. For this POH to be useful, you must tailor it to your specific aircraft. The tail number can easily be changed with a search and replace. Other modifications will take longer, such as references to the trike, tip-up canopy, C/S prop, RMI engine monitor, internal ski rack, etc.

Most performance figures (fuel flow, endurance, speed, ROC, glide performance, etc) were obtained from actual test data.

The Annual Condition Inspection forms should be manually placed at the end of the document after it is printed. I found it beneficial to print the checklists out separately and use them during the preflight (pages 7-12, 26-29).

This document is best used when printed on a color printer. The 8 1/2" X 11" paper should be cut to the proper size after printing.

The Annual Condition Inspection was taken from the RV-List. I think it was originally written by George Orndorff. The Van's Airforce logo was downloaded from the internet and I have no idea of the original artist. If George or the designer of the logo objects to these being included in the POH, I will remove them from all further distributions.

This POH can be considered "freeware". It is distributed free of charge. You may pass it on to anyone else as long as this title page remains intact.

I am not a technical writer and make no warrantee as to the accuracy of the information contained in the enclosed document. You MUST review, modify and be comfortable with the enclosed information PRIOR to using it as a preflight/ in-flight reference. Due to the nature of homebuilt aircraft, I feel it is impossible to develop one standard POH to cover all RV-6A's, -6's, etc. Use the enclosed information at your own risk. If you don't agree with this disclaimer, just delete this entire document and get on with your life.

This document is still under constant revision. If anyone has any ideas on how it can be improved, please let me know. I hope this is of help to others.

Scott Gesele N506RV – Flying
scottg@icsnet.com

Starting from Scott's template that had been modified by another user, I modified it again to make it closer to the Cessna 172 POH by respecting the same paragraph order, subjects and populating the Performance and System description.

It is in a pre-flight test state now, performance to be populated and procedures are expected to change.

RV-9 N178TL

Pilot Operating Handbook

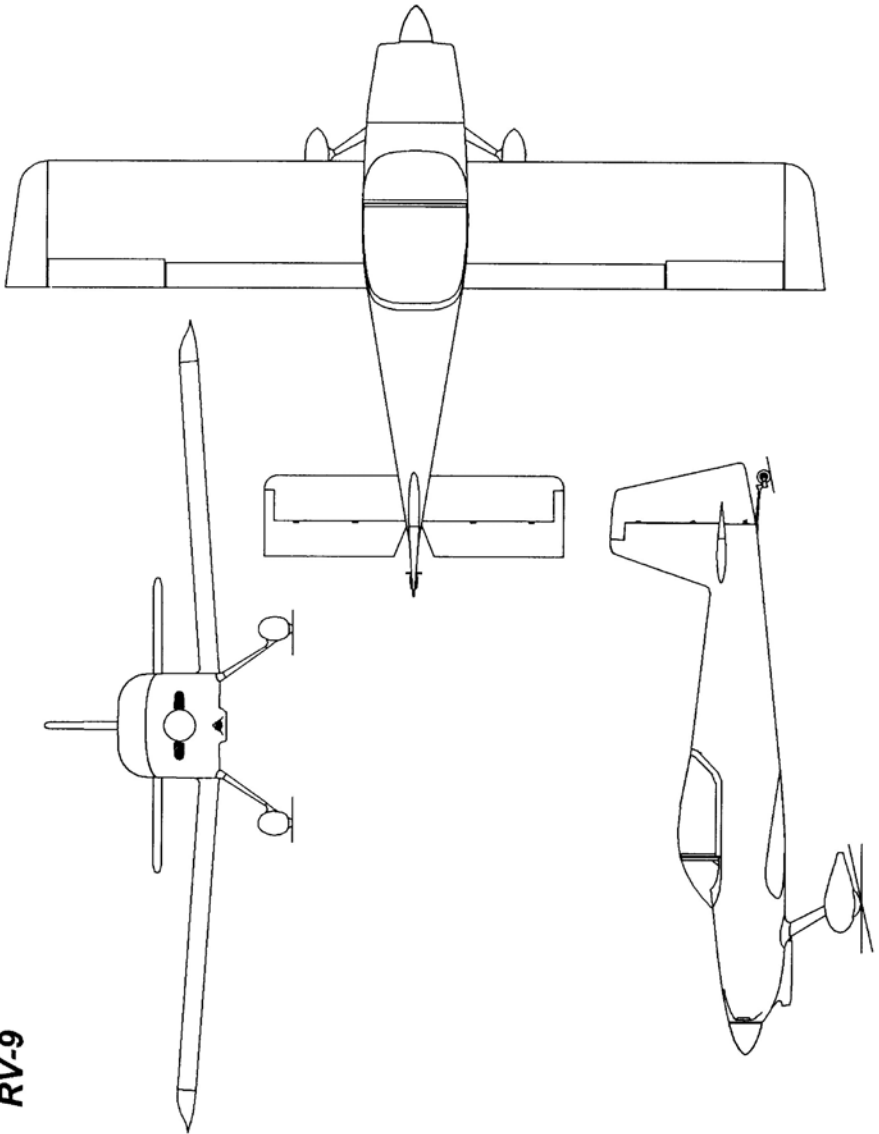

RV-9

RV-9 N178TL

Pilot Operating Handbook



GENERAL

SPAN 28' 0"
 LENGTH 20' 5"
 HEIGHT 6' 0"

ENGINE Lycoming O-320-B1A1N
 HORSEPOWER 160 HP @ 2600 RPM
 OIL GRADE AND VISCOSOTY:

Average	MIL-L-6082	MIL-L-22851
Ambient Air	Mineral	Ashless Dispersant
All Temperatures	-----	SAE 15W50 or 20W50
Above 80° F	SAE 60	SAE 60
Above 60° F	SAE 50	SAE 40 or SAE 50
30° F to 90° F	SAE 40	SAE 40
0° F to 70° F	SAE 30	SAE 40, 30 or 20W40
0° F to 90° F	SAE 20W50	SAE 20W50 or 15W50
Below 10° F	SAE 20	SAE 30 or 20W30

OIL CAPACITY 8 Qts max

PROPELLER..... Sensenich, 2-Blade Aluminum, 70CM6S9-0-80

FUEL: Capacity 52 US Gal Total
 Type: 91/96 or 100LL Avgas

MAXIMUM WEIGHT (Normal Category) 1800 Lbs
 EMPTY WEIGHT 1090 Lbs
 MAXIMUM USEFUL LOAD 710 Lbs
 BAGGAGE ALLOWANCE 100 Lbs

WING LOADING (Pounds/ Sq. Ft) 14.5 lb/sqft
 POWER LOADING (Pounds/ HP) 11.0 lb/hp
 GLIDE RATIO @ 78 KIAS 12.7 :

1

RV-9 N178TL

Pilot Operating Handbook



LIMITATIONS

AIRSPEED LIMITATIONS

	SPEED	IAS	REMARKS
V_{NE}	Never Exceed Speed	182 KIAS	Do not exceed this speed in any operations.
V_{NO}	Maximum Structural Cruising Speed	156 KIAS	Exceed this speed only in smooth air.
V_A	Maneuvering Speed	103 KIAS	Do not make full control movements above this speed. Full elevator deflection will result in a 4.4g load at this speed.
V_{FE}	Maximum Flap Extended Speed	78 KIAS	Do not exceed this speed with flaps down
V_y	Best Rate of Climb	75 KIAS	
V_x	Best Angle of Climb	64 KIAS	
V_s	Stall Speed Clean	49 KIAS	
V_{so}	Stall Speed Landing Configuration	43 KIAS	

RV-9 N178TL

Pilot Operating Handbook



AIRSPEED INDICATOR MARKINGS

MARKING	KIAS VALUE OR RANGE	SIGNIFICANCE
White Arc	43 – 78 KIAS	Full Flap Operating Range. Lower limit is V _{so} . Upper limit is maximum speed with flaps extended
Green Arc	49 – 156 KIAS	Normal Operating Range. Lower limit is V _s . Upper limit is maximum structural cruising speed
Yellow Arc	156 – 182 KIAS	Operations must be conducted with caution and only in smooth air.
Blue Line	103 KIAS	Maneuvering speed – Max. permissible speed at which full control can be applied.
Red Line	182 KIAS	Maximum speed for all operations

POWER PLANT LIMITATIONS

Model: ECI Titan O320-B1A1N

Max Power:164 hp @ 2700 RPM

NOTE: Propeller limited to 2600 RPM Max

Fuel: 91/96 or 100 LL

Oil Filter: Champion CH48108-1 or equivalent

Oil: Aeroshell 100

Oil Sump Capacity 8 U.S. Quarts

Normal Quantity 5- 6 U.S. Quarts

RV-9 N178TL

Pilot Operating Handbook



Minimum Safe Quantity ...2 U.S. Quarts
Maximum Consumption ...0.67 U.S. Quart / Hour Max

Oil Inlet Temp: 180° F desired
245° F Max
Oil Pressure: 90 psi Max, 60 psi Min
75 – 85 psi desired
25 psi idle
Fuel Pressure:8 psi Max, 0.5 psi Min
2 – 5 psi desired
CHT: 500° F Max
150 to 435° F continuous operation

WEIGHTS LIMITS:

Utility Category..... 1600 Lbs
Normal Category 1800 Lbs
Forward CG Limit 15% of chord, or
7.95" aft of leading edge
Normal Aft CG Limit 28% of chord, or
14.84" aft of leading edge
Utility Aft CG Limit 24% of Chord, or
12.72" aft of leading edge

NOTE: This airplane is not designed for aerobatic flight but it can perform normal flight training maneuvers when operated in the Utility category.

Spins are prohibited.

Abrupt use of controls is prohibited above 103 KIAS.

FLIGHT LOAD FACTOR LIMITS:

Utility Category (MTOW 1600 lbs.)..... +4.4g, -1.8G

RV-9 N178TL

Pilot Operating Handbook



OPERATION LIMITS:

Flight into known icing condition is prohibited.

The airplane is equipped for day and night VFR.

The airplane is equipped with a mode C transponder with altitude encoding.

FUEL LIMITATIONS:

The airplane is equipped with 4 fuel tanks, 2 inboard wing leading edge and 2 wing tip tanks.

Total useable fuel: 52 U.S. gallons

Wing Tank (2): 36 U.S. gallons usable + 0.2 unusable

Tip Tank (2): 16 U.S gallons usable + 0.5 unusable

Allowed fuel: AVGAS 100LL (Blue)

Take-off and land with fuel selector on the fullest tank position.

FLAP LIMITATIONS:

Flap deployment up to 15°: 87 KIAS Max

Flap deployment 15° to 32°: 78 KIAS Max

RV-9

N178TL

Pilot Operating Handbook



EMERGENCY PROCEDURES

AIRSPEEDS

Engine Failure After Takeoff	60 KIAS
Maneuvering Speed (Va)	103 KIAS
Maximum Glide	78 KIAS
Landing Without Engine Power	60 KIAS

ENGINE FAILURES

ENGINE FAILURE DURING TAKEOFF RUN

1. Throttle – IDLE
2. Brakes – APPLY
3. Wing Flaps – RETRACT
4. Mixture – IDLE CUT-OFF
5. Ignition Switch – OFF
6. Master Switch – OFF

ENGINE FAILURE IMMEDIATELY AFTER TAKEOFF

1. Airspeed – 60 KIAS
2. Fuel Selector Valve – OFF
3. Mixture – IDLE CUT-OFF
4. Ignition Switch – OFF
5. Wing Flaps – AS REQUIRED
6. Master Switch – OFF

ENGINE FAILURE DURING FLIGHT

1. Airspeed – 78 KIAS
2. Select suitable landing spot and turn to it
3. Fuel Selector – SWITCH TANK
4. Mixture – RICH
5. Carburetor Heat – ON
6. Fuel Pump – ON
7. Ignition Switch – START
8. If no start – EMERGENCY LANDING

RV-9

N178TL

Pilot Operating Handbook



EMERGENCY OPERATIONS LANDING

EMERGENCY LANDING

1. AVIATE – NAVIGATE – COMMUNICATE
2. Airspeed – 60 KIAS
3. Select suitable landing spot and turn to it
4. Harness – SECURE
5. Fuel Selector – OFF
6. Fuel Pump – OFF
7. Ignition Switch – OFF
8. Transponder – 7700
9. COMMUNICATE – TRANSMIT MAYDAY on 121.5
10. Canopy – Unlatch overhead and side releases
11. Flaps – As needed
12. Master – OFF
13. Touch down at minimum controllable airspeed

DITCHING (WATER LANDING)

EMERGENCY WATER LANDING

1. AVIATE – NAVIGATE – COMMUNICATE
2. Airspeed – 60 KIAS
3. Select suitable landing spot close to shore, if possible.
4. APPROACH – High Winds, Heavy Seas – INTO THE WIND
– Light Winds, Heavy Swells – PARALLEL TO SWELLS
5. COMMUNICATE – TRANSMIT MAYDAY on 121.5
6. Transponder – 7700
7. Canopy – Unlatch overhead and side releases
8. Harness – SECURE (Brief passenger on Release Mechanism.)
9. Heavy Objects – SECURE (Remove object from glare shield.)
10. Fuel Selector – OFF
11. Fuel Pump – OFF
12. Ignition Switch – OFF
13. Flaps – FULL
14. Master – OFF
15. Touch down – 2 MPH above stall speed
16. Face – CUSHION at touchdown with folded coat
17. Airplane – EVACUATE
18. Life Vests and Raft - INFLATE



EMERGENCY OPERATIONS FIRES

DURING START ON GROUND

1. Cranking – CONTINUE, to get a start which would suck the flames and accumulated fuel through the servo and into the engine.

If engine starts:

2. Power – 1700 RPM for a few minutes
3. Engine – SHUTDOWN and inspect for damage

If engine fails to start:

1. Throttle – FULL OPEN
2. Mixture – IDLE CUT-OFF
3. Cranking – CONTINUE
4. Fuel Selector – OFF
5. Ignition Switch – OFF
6. Master Switch – OFF
7. Fire Extinguisher – OBTAIN
8. Fire – EXTINGUISH

ENGINE FIRE IN FLIGHT

1. Fuel Selector Valve – OFF
2. Mixture – IDLE CUT-OFF
3. Master Switch – OFF
4. Cabin Heat and Air – OFF
5. Forced Landing - EXECUTE

ELECTRICAL FIRE IN FLIGHT

1. Master Switch – OFF
2. Avionics Master – OFF
3. All Other Switches (except magneto) – OFF
4. Vents/ Cabin Air/ Heat – CLOSED
5. Fire Extinguisher – ACTIVATE
6. Master Switch and C/B – ON ONE C/B AT A TIME

CABIN FIRE

1. Master Switch – OFF
2. Vents/ Cabin Heat – CLOSED
3. Fire Extinguisher – ACTIVATE (if available)

RV-9 N178TL

Pilot Operating Handbook



EMERGENCY OPERATIONS

FIRES - continued

WING FIRE

1. Nav & Strobe Lights – OFF
2. Pitot Heat – OFF
3. Landing Lights – OFF

ICING

1. Pitot Heat – ON
2. Turn Back or Change Altitude
3. Cabin Heat – ON
4. Defog Fan – ON
5. Throttle – HIGH RPM TO MINIMIZE ICE BUILDUP
6. Carburetor Heat – ON
7. Precautionary Landing – NEAREST AIRPORT
8. Approach Airspeed with ice buildup – 60 – 70 KIAS

ELECTRICAL

ALTERNATOR FAILURE – UNDER OR OVERVOLTAGE

1. Util and Alternator Feed C/B – RESET

If Alternator is Still Faulty:

2. Util and Alternator Feed C/B – PULL
3. Dynon C/B – PULL
4. PC NAV C/B – PULL
5. Nonessential Electrical Equipment, Lights – OFF
6. Flight – TERMINATE as soon as practical.

NOTE: The main battery when fully charged will sustain 3hrs operation on minimum power demand.

RV-9 N178TL

Pilot Operating Handbook



NORMAL PROCEDURES

PREFLIGHT INSPECTION

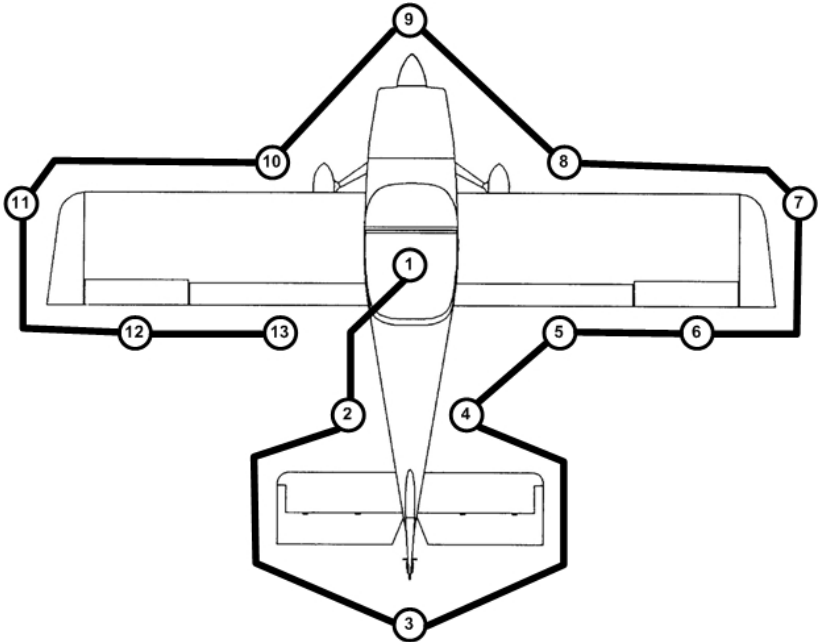

1. CABIN

1. Documentation – Available In Airplane
2. Aeronautical Charts – CURRENT AND APPROPRIATE TO FLIGHT
3. Flight Control Locks – RELEASE
4. Ignition Switches – OFF
5. Avionics Switch – OFF
6. Master Switch – ON

WARNING

When turning on the master switch, using an external power source, or pulling the propeller through by hand, treat the propeller as if the

RV-9 N178TL

Pilot Operating Handbook



ignition switches were on. Do not stand, nor allow anyone else to stand, within the arc of the propeller, since a loose or broken wire, or a component malfunction, could cause the propeller to rotate.

7. Dynon Battery – ON
8. Fuel Quantity – CHECK QUANTITY – VERIFY ENGINE MONITOR RESET
9. Times – RECORD TACH, HOBBS ON SHEET
10. Fuel Selector Valve – LEFT TANK
11. Fuel Pump – ON – VERIFY FUEL PRESSURE
12. Fuel Pump – OFF
13. Flaps – DOWN
14. Master Switch and Dynon – OFF

2. STATIC PORT

1. Static Sources – CHECK for blockage

3. EMPENNAGE

1. Tail Tie-Down – DISCONNECT
2. Tail Wheel – Check condition and Locked
3. Tail Wheel Tire – CHECK for proper inflation (40-45 psi)
4. Control Surfaces – CHECK freedom of movement and security

4. STATIC PORT

1. Static Sources – CHECK for blockage

5-6. RIGHT WING AFT

1. Flap – CHECK security and travel
2. Aileron – CHECK freedom of movement and security

7. RIGHT WING TIP

1. Navigation and Strobe Light – CHECK condition
2. Landing Light – CHECK condition
3. Tip Tank Fuel Quantity – CHECK VISUALLY
4. Tip Tank Fuel Filler Cap – SECURE
5. Tip Tank – SUMP
6. Tip Tank Vents – CHECK for blockage

RV-9 N178TL

Pilot Operating Handbook



8. RIGHT WING FRONT

1. Wing Tie-Down – DISCONNECT
2. Stall Detector – CHECK for blockage
3. Main Tank Fuel Quantity – CHECK VISUALLY
4. Main Fuel Filler Cap – SECURE
5. Main Wheel Tire – CHECK for proper inflation (30-35 psi)
6. Chock – REMOVE
7. Right Main Wing Tank – SUMP

9. NOSE

1. Engine Oil Level – CHECK, do not operate with less than 5 quarts
2. Gascolator – SUMP
3. Propeller and Spinner – CHECK for nicks and security
4. Cowl Camlocks – CHECK for security
5. Air Inlet – CHECK for restrictions
6. Fuel Tank Vents – CHECK for blockage

10. LEFT WING FRONT

1. Main Wheel Tire – CHECK for proper inflation (30-35 psi)
2. Chock – REMOVE
3. Left Main Wing Tanks – SUMP
4. Main Tank Fuel Quantity – CHECK VISUALLY
5. Main Tank Fuel Filler Caps – SECURE
6. Pitot Tube Cover – REMOVE and check for blockage
7. Wing Tie-Down – DISCONNECT

11. LEFT WING TIP

1. Landing Light – CHECK condition
2. Navigation and Strobe Light – CHECK condition
3. Tip Tank Fuel Quantity – CHECK VISUALLY
4. Tip Tank Fuel Filler Cap – SECURE
5. Right Tip Tank – SUMP
6. Tip Tank Vents – CHECK for blockage

12-13. LEFT WING AFT

1. Aileron – CHECK freedom of movement and security
2. Flap – CHECK security and travel

RV-9 N178TL

Pilot Operating Handbook



NORMAL OPERATING PROCEDURES

BEFORE STARTING ENGINE

1. Preflight Inspection – COMPLETE
2. Cabin and Baggage Compartment – CLEAN and SECURE
3. Seat Belts and Shoulder Harnesses – ADJUST and LOCK
4. Fuel Selector Valve – LEFT TANK
5. Circuit Breakers – IN
6. Master Switch – OFF
7. Avionics Master – OFF
8. Brakes – SET

STARTING ENGINE

1. Dynon – ON
2. Master Switch – ON
3. Strobe – ON
4. Flaps – UP
5. Mixture – RICH
6. Carb Heat – COLD
7. Fuel Pump – ON check pressure
8. Primer – AS REQUIRED (3 to 5 seconds, none if engine warm)
9. Fuel Pump – OFF
10. Throttle – OPEN 1/8 INCH
11. Propeller Area – CLEAR
12. Ignition – START
13. Throttle – ADJUST to 1000 rpm
14. Oil Pressure – CHECK 25 psi minimum at idle
15. Avionics Master, Radio and Motion PC – ON

BEFORE TAXI

1. Brakes – SET
2. Mixture – LEAN @ 1000 RPM
3. Flight Controls – FREE and CORRECT
4. ATIS and Clearance Delivery – AS REQUIRED
5. Radio & Transponder – SET FREQUENCIES
6. Motion PC – LOAD FLIGHT PLAN/RECORDER
7. Brakes – RELEASE AND VERIFY

RV-9 N178TL

Pilot Operating Handbook



BEFORE TAKEOFF – RUNUP

1. Brakes – SET
2. Canopy – Overhead Latch – SECURE
3. Altimeter and EFIS – CORRECT BARO PRESSURE
4. Elevator and Aileron Trim – NEUTRAL
5. Flaps – UP
6. Fuel Selector Valve – DESIRED TANK
7. Flight Controls – FREE and CORRECT
8. Oil Temp - 140°F MIN
9. Mixture – RICH
10. Throttle – 1700 RPM:
 - a. Left Magneto – 50 TO 150 RPM DROP
 - b. Right Magneto – 0 TO 50 RPM DROP
 - c. Carburetor Heat – CHECK THEN COLD
 - d. Engine Instruments – CHECK
11. Throttle – IDLE, THEN 1000 RPM
12. Fuel Pump – ON
13. Transponder – ALT
14. Landing Light – ON
15. Brakes – RELEASE

TAKEOFF

NORMAL TAKEOFF

1. Wing Flaps – UP
2. Mixture – RICH
3. Throttle – FULL OPEN
4. Stick – LIFT TAIL WHEN RUDDER EFFECTIVE
5. Take-off – ROTATE AT 55 KIAS
6. Climb Speed – 78 KIAS

SHORT FIELD TAKEOFF

1. Wing Flaps – 10°
2. Brakes – APPLY
3. Stick – FULL BACK
4. Throttle – FULL OPEN
5. Mixture – RICH (above 3000 feet, LEAN to obtain max RPM)

RV-9 N178TL

Pilot Operating Handbook



6. Brakes – RELEASE
7. Stick – LIFT TAIL WHEN RUDDER EFFECTIVE
8. Climb Speed – 58 KIAS (until obstacles cleared) **TBC**

ENROUTE CLIMB

1. Airspeed – 96 - 113 KIAS
2. Throttle – 25 IN Hg or FULL OPEN
3. Mixture – RICH (above 3000ft lean to max RPM)

CRUISE

1. Throttle – 45% TO 65% POWER
2. Trim – ADJUST
3. Mixture – LEAN as necessary

DESCENT

1. Mixture – FULL RICH
2. Throttle – ADJUST AS REQUIRED
3. Carburetor Heat – ON

BEFORE LANDING

1. Seat Belt – SECURE
2. Fuel Pump – ON
3. Landing Lights – ON
4. Fuel Selector – TO FULLEST TANK
5. Mixture – FULL RICH
6. Carburetor Heat – AS REQUIRED
7. Airspeed – Slow down to 60 – 70 KIAS
8. Flaps – as needed below 78 KIAS

LANDING

For wing gust divide gust by 2 and add to landing/approach speed in addition to crosswind factor.

NORMAL LANDING

1. Airspeed – 60 – 70 KIAS
2. Wing Flaps – FULL DOWN
3. Airspeed – 55 – 60 KIAS
4. Landing – 3 POINT
5. Braking – MINIMUM REQUIRED

RV-9 N178TL

Pilot Operating Handbook



SHORT FIELD LANDING

1. Airspeed – 60-70 KIAS
2. Wing Flaps – FULL DOWN
3. Airspeed – 55 KIAS
4. Landing – 3 POINT
5. Braking – AS REQUIRED, STICK FULL BACK
6. Wing Flaps – RETRACT

GO-AROUND

1. Throttle – FULL OPEN
2. Carburetor Heat – COLD
3. Wing Flaps – RETRACT
4. Airspeed – 70 KIAS

POST FLIGHT

AFTER LANDING

1. Transponder – STANDBY
2. Carburetor Heat – COLD
3. Mixture – LEAN @ 1000 RPM
4. Wing Flaps – RETRACT
5. Landing Lights – OFF
6. Fuel Pump – OFF

ENGINE SHUTDOWN

1. Transponder – STANDBY
2. Avionics Master – OFF
3. Throttle – IDLE
4. Ignition Switches – OFF MOMENTARILY
5. Mixture – IDLE CUT-OFF
6. Ignition Switch – OFF
7. Strobe and Lights – OFF
8. Master Switch – OFF
9. Motion PC Nav – OFF
10. Record tach time from Dynon
11. Dynon battery switch – OFF
12. Headset Power – OFF
13. Fuel Selector Valve – OFF

RV-9 N178TL

Pilot Operating Handbook



SECURING AIRCRAFT

1. Wheel Chocks – INSTALL
2. Wing & Tail Tie-Down – INSTALL AS REQUIRED
3. Pitot Tube Cover – INSTALL AS REQUIRED
4. Cockpit – CLEAN AND SECURE CONTROLS
5. Master and Electrical Switches – OFF

PRELIMINARY

RV-9 N178TL

Pilot Operating Handbook



PERFORMANCE

AIRSPEED CALIBRATION

FLAPS UP KIAS	55	65	85	105	120	135
	KCAS	56	66	89	109	127
ALT STATIC* FLAPS → KIAS	32°	32°	32°	0°	0°	0°
	KCAS	55	65	85	105	105

* Alternate Static Air source selected

STALL SPEEDS

CONDITIONS: Power Off
AIRSPEED: KIAS

WEIGHT LBS	FLAP	ANGLE OF BANK			
		0°	30°	45°	60°
1500 FWD CG	0°	47	51	54	
	32°	40	42	46	
1800 AFT CG	0°	49			
	32°	42			

RV-9 N178TL

Pilot Operating Handbook



TAKEOFF DISTANCE

CONDITIONS:

- Flaps Up;
- Full Throttle before brake release;
- Above 3000 feet elevation, lean mixture to get Max RPM;
- Decrease distance 10% for each 9 knots headwind;
- Increase 10% for each 2 knots tailwind;
- For operation on grass, increase ground roll by 15%.

WEIGHT LBS	TAKEOFF SPEED KIAS		PRESS ALT FT	0°C		20°C		40°C	
	LIFT OFF	AT 50 FT		GRND ROLL FT	CLEAR 50FT OBS	GRND ROLL FT	CLEAR 50FT OBS	GRND ROLL FT	CLEAR 50FT OBS
1800	53*	64 **	S.L.			525			
			2500						
			5000						
1650			S.L.						
			2500						
			5000						
1500			S.L.			350			
			2500						
			5000						

*Stall speed +4

**Best Angle, to be confirmed

MAXIMUM RATE OF CLIMB

CONDITIONS:

- Flaps Up;
- Full Throttle;
- Above 3000 feet elevation, lean mixture to get Max RPM;

WEIGHT LBS	PRESS ALT FT	CLIMB SPEED* KIAS	RATE OF CLIMB – FPM			
			-20°C	0°C	20°C	40°C
1500	S.L.					
	2500					
	5000					
	10,000					
1800	S.L.					
	2500	78	1475	1355	1250	1150
	5000	75	1300	1200	1100	965
	10,000	72	715	660	600	530

*Bold = test data, remaining estimated

RV-9 N178TL

Pilot Operating Handbook



CLIMB & DESCENT TIME, DISTANCE, AND FUEL

CONDITIONS:

- **Climb:** 75% power, 90 KIAS, 8.4GPH;
- **Descent:** 35% power, 125 KIAS, 4.4GPH;
- Add 1.1 US gallon fuel for start, taxi, and takeoff;
- Increase time, fuel, and distance 10% for each 10°C above standard temperature;
- Gross Weight 1800 Lbs;
- Distance for zero wind.

Time(min)/Distance(NM)/Fuel(US Gal)

Density Altitude (Std Atm)		To						
		1500	3500	5500	7500	9500	11500	13500
From	1500		2.1/3.4/0.3	4.6/7.4/0.6	7.5/12.5/1.0	6.8/18.4/1.4	14.5/25.2/1.8	18.6/33.0/2.3
	3500	3.8/8.2/0.3		2.5/4.0/0.3	5.4/9.1/0.7	4.7/15.0/1.1	12.4/21.8/1.5	16.5/29.6/2.0
	5500	7.8/17.1/0.6	4.0/8.9/0.3		2.9/5.1/0.4	6.2/11.0/0.8	9.9/17.8/1.2	14.0/25.6/1.7
	7500	11.4/25.4/0.9	7.6/17.2/0.6	3.6/8.3/0.3		3.3/5.9/0.4	7.0/12.7/0.8	11.1/20.5/1.3
	9500	14.1/31.8/1.1	10.3/23.6/0.8	6.3/14.7/0.5	2.7/6.4/0.2		3.7/6.8/0.4	7.8/14.6/0.9
	11500	16.8/38.3/1.3	13.0/30.1/1.0	9.0/21.2/0.7	5.4/12.9/0.4	2.7/6.5/0.2		4.1/7.8/0.5
	13500	19.5/44.8/1.5	15.7/36.6/1.2	11.7/27.7/0.9	8.1/19.4/0.6	5.4/13.0/0.4	2.7/6.5/0.2	

RV-9 N178TL

Pilot Operating Handbook



CRUISE PERFORMANCE

PRESSURE ALTITUDE FT	% BHP	FUEL FLOW GPH	AIRSPEED KTAS		
			20°C BELOW STD TEMP	STANDARD TEMPERATURE	20°C ABOVE STD TEMP
2500	75	8.4	147	149	151
	65	7.3	137	139	141
	55	6.2	133	135	137
3500	75	8.4	149	151	153
	65	7.3	139	141	143
	55	6.2	135	137	139
4500	75	8.4	151	153	155
	65	7.3	141	143	145
	55	6.2	133	135	137
5500	75	8.4	153	155	157
	65	7.3	144	146	148
	55	6.2	130	132	134
6500	75	8.4	154	156	158
	65	7.3	144	146	148
	55	6.2	131	133	135
7500	75	8.4	156	158	160
	65	7.3	145	147	149
	55	6.2	132	134	136
8500	75	8.4	156	158	160
	65	7.3	146	148	150
	55	6.2	135	137	139
9500	75	8.4	156	158	160
	65	7.3	148	150	152
	55	6.2	143	141	143
10500	75	8.4	160	162	164
	65	7.3	150	152	154
	55	6.2	140	142	144
11500	75	8.4	162	164	166
	65	7.3	153	155	157
	55	6.2	142	144	146

VAN'S AIRSPEEDS:

Maximum at Sea Level 171 KTAS
 Cruise, 75% Power at 8,000 Ft 164 KTAS
 Cruise, 55% Power at 8,000 Ft 147 KTAS
 Vno = 156 KTAS

RV-9 N178TL

Pilot Operating Handbook



LANDING DISTANCE

CONDITIONS: 3 POINT, SHORT FIELD

- Flaps 32°;
- Maximum braking without affecting control;
- Paved, level, dry runway;
- Decrease distance 10% for each 9 knots headwind;
- Increase 10% for each 2 knots tailwind;
- For operation on grass, increase ground roll by 45%.

WEIGHT LBS	SPEED AT 50 FT KIAS	PRESS ALT FT	0°C		20°C		40°C	
			GRND ROLL FT	CLEAR 50FT OBS	GRND ROLL FT	CLEAR 50FT OBS	GRND ROLL FT	CLEAR 50FT OBS
1800	48* TBD	S.L.			450			
		2500						
		5000						
1650		S.L.						
		2500						
		5000						
1500		S.L.			300			
		2500						
		5000						

*Stall speed +6

CONDITIONS: WHEELER, LONG RUNWAY (FOR AFT C.G.)

- Flaps 32°;
- Keep power during flare;
- Braking after deceleration and tail down;
- Paved, level, dry runway;
- Decrease distance 10% for each 9 knots headwind;
- Increase 10% for each 2 knots tailwind;
- For operation on grass, increase ground roll by 45%.

WEIGHT LBS	SPEED AT 50 FT KIAS	PRESS ALT FT	0°C		20°C		40°C	
			GRND ROLL FT	CLEAR 50FT OBS	GRND ROLL FT	CLEAR 50FT OBS	GRND ROLL FT	CLEAR 50FT OBS
1800	65	S.L.			2500			
		2500						
		5000						
1650		S.L.			2500			
		2500						
		5000						
1500		S.L.			2500			
		2500						
		5000						

*Stall speed +6

RV-9 N178TL

Pilot Operating Handbook



RANGE (VAN'S AIRCRAFT DATA)

CONDITIONS:

- Includes 3 gal. for taxi, takeoff & climb;
- Engine leaned for best economy;
- No wind
- 52 US Gal useable fuel.

75% @ 8000', no reserve	892 nm
55% @ 8000', no reserve	1079 nm
75% @ 8000', one hour (8 gal) reserve	754 nm
55% @ 8000', one hour (8 gal) reserve	913 nm
RATE OF CLIMB AT SEA LEVEL	1,400 fpm
SERVICE CEILING	19,000 ft
TAKEOFF PERFORMANCE	500 ft
LANDING PERFORMANCE	410 ft

WEIGHT AND BALANCE

Make: BEAULIEU LOUIS
 Serial #: 90398

Model: RV-9
 Registration: N178TL

MAXIMUM WEIGHTS AND LIMITS:

W&B Data Sheet Reference: ...	N178TL-Weight-Balance 03JUL10.xls
Aerobatic Category	Not approved for Aerobatics
Utility Category	1600 Lbs
Normal Category	1800 Lbs
Forward CG Limit	15% of chord, or 7.95" aft of leading edge
Normal Aft CG Limit.....	28% of chord, or 14.84" aft of leading edge
Utility Aft CG Limit	24% of Chord, or 12.72" aft of leading edge

Datum: 70 inches forward of wing leading edge (L.E.)

Design C.G. Range: 15% to 28% of wing chord

RV-9 N178TL

Pilot Operating Handbook



7.95" to 14.84" from L.E
77.95" to 84.84" aft of Datum

Wing L.E.: 70 inches aft of datum
Main wheel right: 68.75" aft of datum
Main wheel left : 68.75" aft of datum
Tail wheel: 244.75" aft of datum

Main Fuel Tank: 77.68" aft of datum
Wing Tip Fuel Tank: 88" aft of datum
Pilot and Passenger: 92.7" aft of datum
Baggage: 122" aft of datum
Aircraft weighed empty in level flight attitude (longitudinal reference fuselage longeron); includes 8 qts. of oil, unusable fuel.

RV-9 N178TL

Pilot Operating Handbook



	<u>Weight (lb)</u>	<u>Arm (in)</u>	<u>Moment</u>
Right Wheel	519	68.75	35681
Left Wheel	514	68.75	35338
<u>Tail Wheel</u>	55	244.75	13461
Total	1090		84724

Empty CG = 77.71" aft of datum

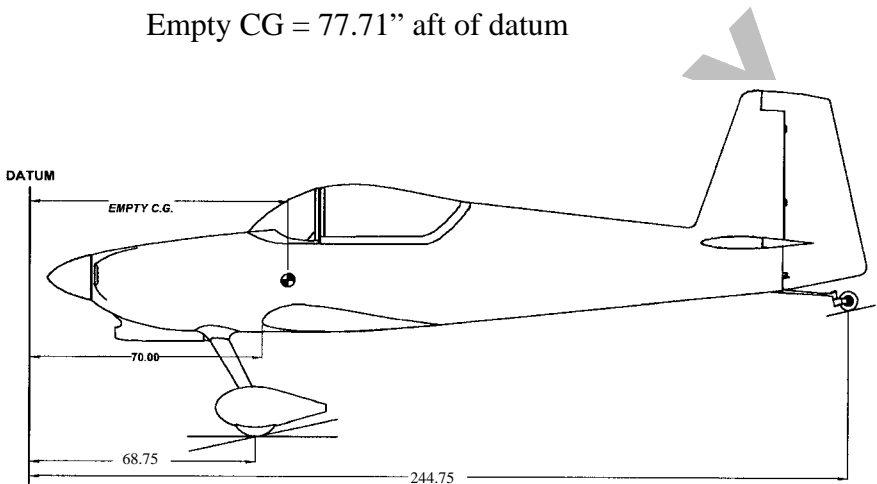

RV-9 N178TL

Pilot Operating Handbook



WEIGHT AND BALANCE DATA

Sample:

	Weight (lb)	Arm (in)	Moment
Aircraft	1090	77.71	84723
Main Fuel (6lbs/gal)	_____	76.75	_____
Tip Fuel (6lbs/gal)	_____	88.00	_____
Pilot	_____	92.70	_____
Passenger	_____	92.70	_____
Fwd Baggage	_____	122	_____
<hr/>			
Total	_____	_____	_____

CG = Total Moment / Total Weight

CG = _____ in aft of datum

CG Range = 77.95 to 84.84 in aft of datum

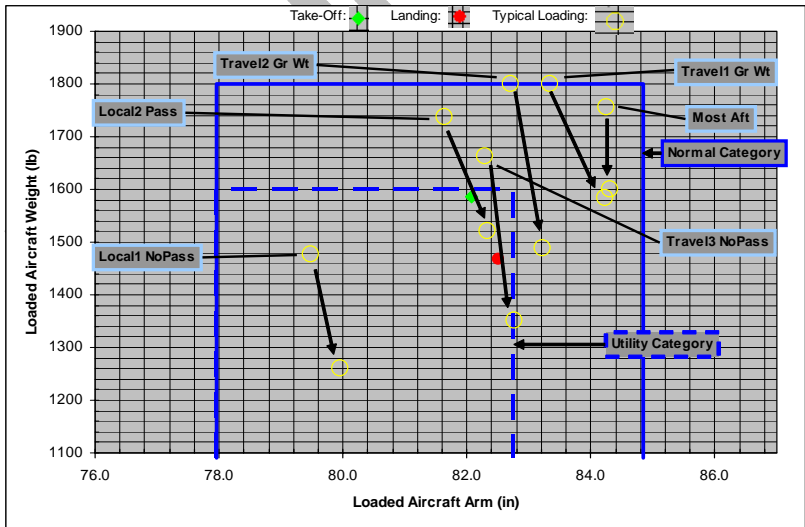

RV-9 N178TL

Pilot Operating Handbook



WEIGHT AND BALANCE TYPICAL LOADS

LOCAL1 FLT (MOST FWD CG): MAIN FUEL, NO PASS

Description	Weight (lbs.)	Moment (lb.-ins.)	Arm
Max Gross Weight	1800		
Empty Weight	1090.3	84723.80	77.71
Take Off Fuel Main amount in Gallons (36 Gal max)	36	16578.00	76.75
Take Off Fuel Tip amount in Gallons (16 Gal max)	0		88.00
Pilot	160	14832.00	92.70
Passenger	0		92.70
Baggage Area (100 lb max)	10	1220.00	122.00
Take-Off Weight and CG	1476.3	117353.80	79.49
Gallons of Fuel Main Used during Flight	36	16578.00	76.75
Gallons of Fuel Tip Used during Flight	0		88.00
Zero fuel Weight and CG	1260.3	100775.80	79.96

LOCAL2 FLT: MAIN FUEL, 250LB PASS, 20LB BAGG

Description	Weight (lbs.)	Moment (lb.-ins.)	Arm
Max Gross Weight	1800		
Empty Weight	1090.3	84723.80	77.71
Take Off Fuel Main amount in Gallons (36 Gal max)	36	16578.00	76.75
Take Off Fuel Tip amount in Gallons (16 Gal max)	0		88.00
Pilot	160	14832.00	92.70
Passenger	250	23175.00	92.70
Baggage Area (100 lb max)	20	2440.00	122.00
Take-Off Weight and CG	1736.3	141748.80	81.64
Gallons of Fuel Main Used during Flight	36	16578.00	76.75
Gallons of Fuel Tip Used during Flight	0		88.00
Zero fuel Weight and CG	1520.3	125170.80	82.33

TRAVEL1 (GR WT): MAIN FUEL, 233LB PASS, 100LB BAG

Description	Weight (lbs.)	Moment (lb.-ins.)	Arm
Max Gross Weight	1800		
Empty Weight	1090.3	84723.80	77.71
Take Off Fuel Main amount in Gallons (36 Gal max)	36	16578.00	76.75
Take Off Fuel Tip amount in Gallons (16 Gal max)	0		88.00
Pilot	160	14832.00	92.70
Passenger	233.7	21663.99	92.70
Baggage Area (100 lb max)	100	12200.00	122.00
Take-Off Weight and CG	1800	149997.79	83.33
Gallons of Fuel Main Used during Flight	36	16578.00	76.75
Gallons of Fuel Tip Used during Flight	0		88.00
Zero fuel Weight and CG	1584	133419.79	84.23

TRAVEL2 (GR WT): FULL FUEL, 160LB PASS, 77LB BAGG

Description	Weight (lbs.)	Moment (lb.-ins.)	Arm
Max Gross Weight	1800		
Empty Weight	1090.3	84723.80	77.71
Take Off Fuel Main amount in Gallons (36 Gal max)	36	16578.00	76.75
Take Off Fuel Tip amount in Gallons (16 Gal max)	16	8448.00	88.00
Pilot	160	14832.00	92.70
Passenger	160	14832.00	92.70
Baggage Area (100 lb max)	77	9394.00	122.00
Take-Off Weight and CG	1799.3	148807.80	82.70
Gallons of Fuel Main Used during Flight	36	16578.00	76.75
Gallons of Fuel Tip Used during Flight	16	8448.00	88.00
Zero fuel Weight and CG	1487.3	123781.80	83.23

TRAVEL3: FULL FUEL, NO PASS, 100LB BAGG

Description	Weight (lbs.)	Moment (lb.-ins.)	Arm
Max Gross Weight	1800		
Empty Weight	1090.3	84723.80	77.71
Take Off Fuel Main amount in Gallons (36 Gal max)	36	16578.00	76.75
Take Off Fuel Tip amount in Gallons (16 Gal max)	16	8448.00	88.00
Pilot	160	14832.00	92.70
Passenger	0		92.70
Baggage Area (100 lb max)	100	12200.00	122.00
Take-Off Weight and CG	1662.3	136781.80	82.28
Gallons of Fuel Main Used during Flight	36	16578.00	76.75
Gallons of Fuel Tip Used during Flight	16	8448.00	88.00
Zero fuel Weight and CG	1350.3	111755.80	82.76

MOST AFT CG: FULL TIP, 250LB PASS, 100LB BAGG

Description	Weight (lbs.)	Moment (lb.-ins.)	Arm
Max Gross Weight	1800		
Empty Weight	1090.3	84723.80	77.71
Take Off Fuel Main amount in Gallons (36 Gal max)	10	4605.00	76.75
Take Off Fuel Tip amount in Gallons (16 Gal max)	16	8448.00	88.00
Pilot	160	14832.00	92.70
Passenger	250	23175.00	92.70
Baggage Area (100 lb max)	100	12200.00	122.00
Take-Off Weight and CG	1756.3	147983.80	84.26
Gallons of Fuel Main Used during Flight	10	4605.00	76.75
Gallons of Fuel Tip Used during Flight	16	8448.00	88.00
Zero fuel Weight and CG	1600.3	134930.80	84.32

FOR ABOVE LOADING CASES CG REMAINS WITHIN LIMITS 77.95 - 84.84 INCHES
 MAX ALLOWABLE PASSENGER WEIGHT IS SET AT 250LB DUE TO LACK OF DATA

RV-9 N178TL

Pilot Operating Handbook



SYSTEMS DESCRIPTION

FLIGHT CONTROLS & TRIM

The Aileron and Elevator controls use push-pull tubes connected to a dual stick. The Aileron control stop are located on the inboard aileron hinge, with one side stopping in one direction, and the other side stopping in the other direction. The Elevator control stop uses the edge of the elevator arm opening in the tail section to limit aileron travel.

The Rudder uses cables to control the rudder position. There is no balance cable and foot pressure on the rudder cable removes the backlash in the cables.

Aileron trim is provided by an electrical actuator through bias springs acting on the aileron controls. The actuator is located between the seats. The Elevator trim is provided from an electrically actuated trim surface mounted on the left elevator. The trim electrical system can be commanded from the hat switch mounted on the pilot stick or from the instrument panel mounted toggle switches. The instrument panel switches have priority over the stick switch using a dedicated relay to provide protection against runaway. See the electrical schematic for details.

The Rudder trim uses a fixed trim tab that can be bent to trim the aircraft longitudinally.

Flaps are electrically operated. The flap deployment speed is low relative to RV-9 cruise speed so airspeed must be lowered before deploying flaps. See the Limitations section for appropriate speeds.

The control surfaces travel limits are the following:

Design Travel in Degrees	Maximum Up/Down	Minimum Up/Down
Aileron	32 / 17	25 / 15
Elevator	30 / 25	25 / 20
Rudder	35 / 35 L/R	30 / 30 L/R
Flaps	32 Down Nominal	-

RV-9 N178TL

Pilot Operating Handbook



INSTRUMENT PANEL

The instrument panel provides the following features, from left to right:

- Cabin Courtesy Light (LED)
- Ignition/Start Switch
- Alternator Fail / Battery ON Light when Engine Off
- Electrical Switches: Master, Avionics, ...
- Dynon D-180
- Aileron/Elevator Trim Indication
- Flap Position Indication
- Motion PC Tablet
- Instrument/Map Light
- Audio Input/Level (Music)
- Intercom and Alternate Mic/Headphone Input
- Primer Solenoid Switch
- Flap Up/Down Switch
- SL-40 VHF Com and GTS 320 Transponder
- Analog Airspeed and Altimeter
- Circuit Breakers
- Trim Toggle Switches
- Alternate Audio (Music) Input
- 12Vdc Outlet
- Defog Fan Switch
- Cabin Air Control
- ELT Remote Control
- Map Box
- Cabin courtesy light (LED).

The following controls are located under the instrument panel, from left to right:

- Dynon Battery Switch
- Parking Brake Control
- Carburetor Heat Control
- Throttle
- Mixture
- Alternate Static Source.

The following controls are located between the seats:

RV-9 N178TL

Pilot Operating Handbook



- Fuel Tank Left/Right/Off selector
- Tip Tank Transfer.

Other miscellaneous controls and instruments:

- Pilot Stick: Coolie Hat Aileron/Elevator Trim Switch, Push To Talk Switch
- Copilot Stick: Push To Talk Switch
- Standby Compass over Glare Shield
- GPS Antenna on Glare Shield

Cabin Equipment:

- Air Vent on Left and Right of Instrument Panel
- Fire Extinguisher between seats
- Can Holder in Front of Pilot/Copilot Seats
- Map Pockets under Left and Right Air Vent
- Pilot and Copilot Headset Connection and mono/stereo switch on Aft Portion of Armrest
- 12Vdc Outlet in Baggage Compartment
- Courtesy Light in Baggage Compartment and Footwell Area
- Sunshade
- Tip-up/Slider Canopy Modification
- Oil/Rag/Toolbox located behind copilot seat

Dynon For-Steer correction card (calibrated 30OCT2010):

For	N	30	60	E	120	150
Steer	00 1	030	059	09 0	120	151
For	S	210	240	W	300	330
Steer	18 0	210	239	27 0	302	332

LANDING GEAR AND BRAKE SYSTEM

The landing gear is a fixed taildragger configuration. The main gear use a spring steel rod, angled backward to provide shock absorption through tire friction. Wood and fiberglass damper are laminated to the main gear to provide additional damping. The tailwheel uses also a spring steel rod.

RV-9 N178TL

Pilot Operating Handbook



The Main wheel use tube type tires and independent disc brakes commanded from the pilot and copilot left and right rudder pedals. The tailwheel uses a solid rubber tire.

- Main Tire Pressure: 30-35 psi

The main wheel fairings may be removed if aircraft is operated on dirt field to prevent dirt accumulation inside.

BAGGAGE COMPARTMENT

The maximum baggage compartment capacity is 100lb based on the floor loading capacity. The cargo net should be used at all times when carrying cargo.

SEAT AND SEAT BELTS

A four point seat belt system is installed. The shoulder straps are connected through the rear bulkhead. The seat is adjustable forward/aft by relocating seat back hinges attached to the floor, and upper support to the seat back. The seat is adjusted up/down by adding/removing cushions.

CANOPY

ENGINE: CONTROLS, INSTRUMENTS, OIL, IGNITION, STARTER, AIR INDUCTION, CARBURETOR AND PRIMING, COOLING

PROPELLER

FUEL SYSTEM

Fuel quantity correction with aircraft on ground: Remove 1 US Gallon from Dynon indicated quantity.

Measurement Stick, Main Tanks:

RV-9 N178TL

Pilot Operating Handbook



Quantity (US Gal)	7	8	9	10	11	12	13	14	15	16	17	18
Height (inch)	1 7/8	2 1/4	2 5/8	3	3 3/8	3 11/16	4	4 7/16	4 13/16	5 1/4	6	7

ELECTRICAL SYSTEM

LIGHTING SYSTEM

CABIN HEATING, VENTILATING AND DEFROSTING SYSTEM

PITOT-STATIC SYSTEM

DYNON ELECTRONIC INSTRUMENT

STALL WARNING SYSTEM

AVIONICS: DYNON, COM, TRANSPONDER, PC NAV

AUDIO CONTROL PANEL

TBD

RV-9 **N178TL**

Pilot Operating Handbook



SERVICE AND MAINTENANCE

New sections:

Airplane Handling, Service & Maintenance

PRELIMINARY